

Die Grinders (Type 1, Type 1 Cut-Off, Type 41 Wheels)

400GT / 400GT+3 / 400GT+6 Series



407GT Series



Guard/Wheel Size	Max. Rated Speed	Exhaust Direction	Lever Style	MODEL NUMBER	Guard/Wheel Size	Max. Rated Speed	Exhaust Direction	Lever Style	MODEL NUMBER
3 Inch (75 mm)	18,000 RPM	Side	Standard Lever	400GTS;18000;301	4 Inch (100 mm)	15,000 RPM	Side	Standard Lever	407GTS;15000;401
			Safety Lever	400GTSK;18000;301				Safety Lever	407GTSK;15000;401
		Rear	Standard Lever	400GTSR;18000;301				Safety Lever	407GTSRK;15000;401
			Safety Lever	400GTSRK;18000;301					

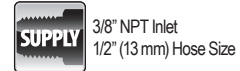
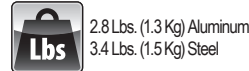
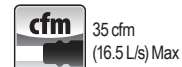
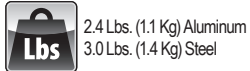
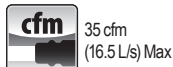
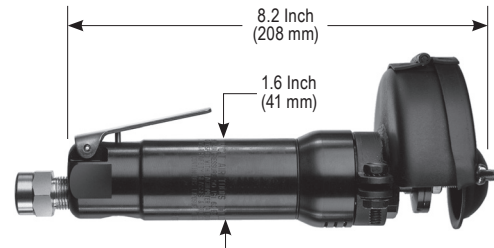
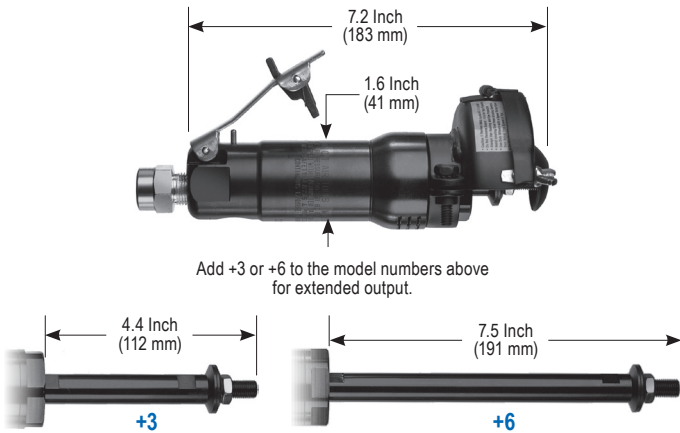

STANDARD EQUIPMENT

- Tool
- Operating Instructions and Service Manual
- Wrenches (sizes based on options)

400GT & 407GT Alternate Options



Type 1 Wheel

